



# CENTRAL CROSSINGS

MONTHLY NEWS LETTER OF THE

CENTRAL RAILWAY  
MODEL & HISTORICAL ASSOCIATION, INC.

Volume 21, Number 9

September 2012

P. O. Box 128  
Central, SC 29630

WEBSITE:  
www.crmha.org

MUSEUM &  
MEETING SITE  
108 Werner Street  
Central, SC

#### OFFICERS

President / CEO:  
Dan Maret

Vice Presidents:  
Joe Fitzpatrick (2<sup>nd</sup>)

Stationmaster  
Ralph Watson

Paymaster  
Bob Folsom

Webmaster  
Ed Welch

Show Chair:  
Jim Reece

Museum Curator:  
Jack Green

Editor & Producer:  
Robert M. Seel, AIA

#### Next Meeting:

**Sept. 6, 2012**

**7:15 PM**

**at the**

**Central Railway  
Museum**

**with**

**another great  
Mac McMillin  
program!**



## SUMMER STEAMS INTO FALL

We've had a great summer season with more steam excursions and heritage diesels than we've seen in a long time. This month, we have even more! Check out **Don Rumer's** report from the OLLI's trip to Cass, West Virginia and Roanoke, Virginia. Also, we have **Bruce Gathman's** monthly patent, **Meeting Minutes**, and more. **Above:** New Hope & Ivyland 2-8-0 No. 40 (ex-Cliffside 40, nee-Lancaster & Chester 40) celebrates her 87<sup>th</sup> birthday after a year-long rehab on Sunday, August 26, 2012. **Photo by Rob Seel.**

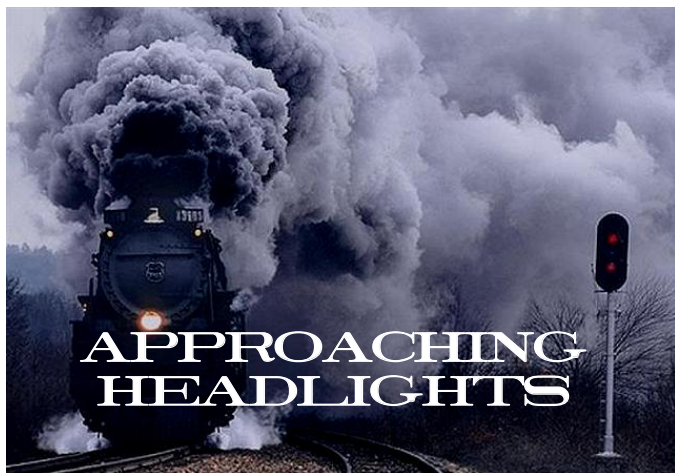

Upcoming Events for the  
**Central Railway Model & Historical Association**  
 as well as Regional shows and events worth  
 mentioning

---

## PROGRAM SCHEDULE

---

September 6, 2012	<b>Local Railroads, Part 2</b> Mac McMillin
October 5, 2012	<b>Dale Reynolds</b> 2012 Tennessee Ramble
November 5, 2012	<b>Patents by CRM&amp;HA</b> <b>Family Relatives</b> Bruce Gathman
December, 2012	<b>Christmas Dinner, TBA</b>
<b>2013 Programs</b>	<b>We are WIDE OPEN for</b> <b>YOU to share your wisdom</b> <b>and experiences. See Dale !</b>

**2<sup>ND</sup> SATURDAY**

**MUSEUM OPEN TO**  
**THE PUBLIC**

**COME RUN TRAINS & HAVE SOME**  
**FUN !**

**SEPT. 8, 2012**  
**OCTOBER 13, 2012**  
**NOVEMBER 10, 2012**

# SCHEDULED EVENTS & SHOWS

**September 14, 15, & 16, 2012**

**Bryson City, NC – Annual RailFest**

Great Smoky Mountains Railroad  
 Motor cars, special excursions and events  
<http://www.gsmr.com/2012-railfest>

**October 13-14, 2012**

**Myrtle Beach, SC – Model RR Show**

Grand Strand Model Railroad Club  
 Lakewood Conference Center  
 Layouts, clinics, sale, etc.  
 Sat 10-5, Sun 10-4 Adults: \$5 / Ages 6-12: \$3  
<http://www.isfans.com/gsmrrc/index.php>

**October 13-14, 2012**

**Fletcher, NC – Autumn Rails 2012**

French Broad e”N”pire  
 WNC Ag Center Expo  
 Layouts, sale, all scales, Live Steam, too!  
 Sat 10-5, Sun 12-4  
 \$6 / Under 12 and uniformed Scouts Free  
[www.fbe-ntrak.com](http://www.fbe-ntrak.com)

**October 13 – November 24, 2012**

**Greater Atlanta, GA**

**10<sup>th</sup> Annual Piedmont Pilgrimage**

Home layout tours!  
 Hosted by the NMRA Piedmont Division  
 Free!! Check the schedule for more info  
<http://www.piedmont-div.org/pilgrimage/>

**October 27-28, 2012**

**Norcross, GA – Great Train Expo**

North Atlanta Trade Center  
 10:00 – 4:00 \$7.00 / Under 12 Free  
<http://www.greattrainexpo.com/info.html>

**November 3-4, 2012**

**Raleigh, NC – Neuse River Valley Show**

State Fairgrounds Exhibition Center  
 9:00 – 5:00 \$6.00 / Under 10 Free  
[http://www.nrclub.net/Annual\\_Show.html](http://www.nrclub.net/Annual_Show.html)

# P A T E N T L Y   S P E A K I N G

*Submitted by Bruce Gathman*

There are generally two parts to patent submissions: a written description of the invention and drawings (not to scale) that are keyed to this written description. Depending on the complexity of the invention more than one page of descriptions and/or drawings may be required to fully explain the merits of the design. You may find these descriptions online at—<http://patft.uspto.gov/netahtml/PTO/patimg.htm> by entering the patent number in the “view patent” box.

Be it known that I,

JOSHUA L. COWEN,

a citizen of the United States, and a resident of New York City, in the county of New York and State of New York, have invented certain new and useful Improvements m Toy Cars, of which the following is a specification.

This invention relates to toy cars. The principal object of the invention is to provide a toy car which is inexpensive to manufacture, is attractive in appearance and durable in use.

In the manufacture of these toy car bodies hitherto, the bottom was made of a separate piece of metal soldered or otherwise secured to the sides. This involved the soldering of a long seam or else other mode of attachment which involved comparatively tedious work. Also in representing the windows, the window frames and doors had to be painted by hand, another tedious hand operation which is often imperfect by reason of the difficulty of preventing smudging. The present invention reduces considerably the hand labor involved by a process in which the bottom is stamped out of one sheet of metal together with the sides and ends, which reduces the soldering to very short seams at the junction of the sides and ends. Also instead of painting the window frames and doors, a separate sheet of different colored metal is stamped out to register with the window and door openings at the sides and secured inside of the car in proper registration with the window and door openings by simple attaching means.

The various further id subsidiary objects and advantages more fully appear from the following detailed description and the features of novelty will be particularly pointed out in the claims.

In the drawings illustrating this invention, Figure 1 is a plan view, and Fig. 2 is a profile view of the blank after it is punched out in the first process. Fig. 3 is a side elevation and Fig. 4 is an end elevation of the car body as it appears after the sides and ends are bent up in the second step of the process. Fig 5 is an elevation of the different colored plate inserted in the interior of the car body Fig. 6 is a section taken along line 6—6 of Fig. 5. Fig. 7 is an enlarged cross sectional elevation of the car body at the end of the second step of the process, the section being taken along line 7—7 of Fig. 3. Fig. 8 is a full-size side elevation illustrating the appearance of the car body after the different colored plate is inserted in the inside. Fig. 9 is a section taken along line 9—9 65 of Fig. 8. Fig. 10 is a fragmental sectional view illustrating the mode of securing the interior plates in position.

# PATENTLY SPEAKING

Submitted by Bruce Gathman

There are generally two parts to patent submissions: a written description of the invention and drawings (not to scale) that are keyed to this written description. Depending on the complexity of the invention more than one page of descriptions and/or drawings may be required to fully explain the merits of the design. You may find these descriptions online at—<http://patft.uspto.gov/netahtml/PTO/patimg.htm> by entering the patent number in the “view patent” box.

J. L. COWEN.  
TOY CAR.  
APPLICATION FILED OCT. 23, 1915.

1,272,390.

Patented July 16, 1918.

2 SHEETS—SHEET 1.

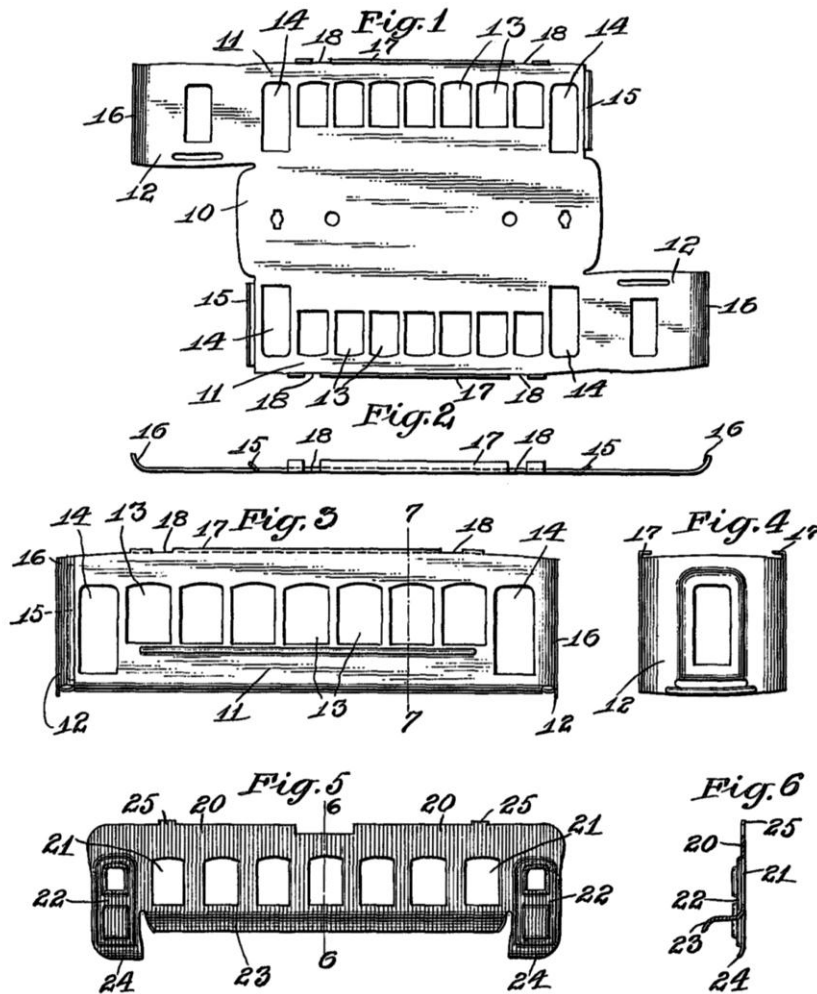

Inventor  
Joshua L. Cowen  
By his Attorneys  
Ashley & Pleshan

# PATENTLY SPEAKING

*Submitted by Bruce Gathman*

There are generally two parts to patent submissions: a written description of the invention and drawings (not to scale) that are keyed to this written description. Depending on the complexity of the invention more than one page of descriptions and/or drawings may be required to fully explain the merits of the design. You may find these descriptions online at—<http://patft.uspto.gov/netahtml/PTO/patimg.htm> by entering the patent number in the “view patent” box.

J. L. COWEN.  
TOY CAR.  
APPLICATION FILED OCT. 23, 1915.

1,272,390.

Patented July 16, 1918.  
2 SHEETS—SHEET 2.

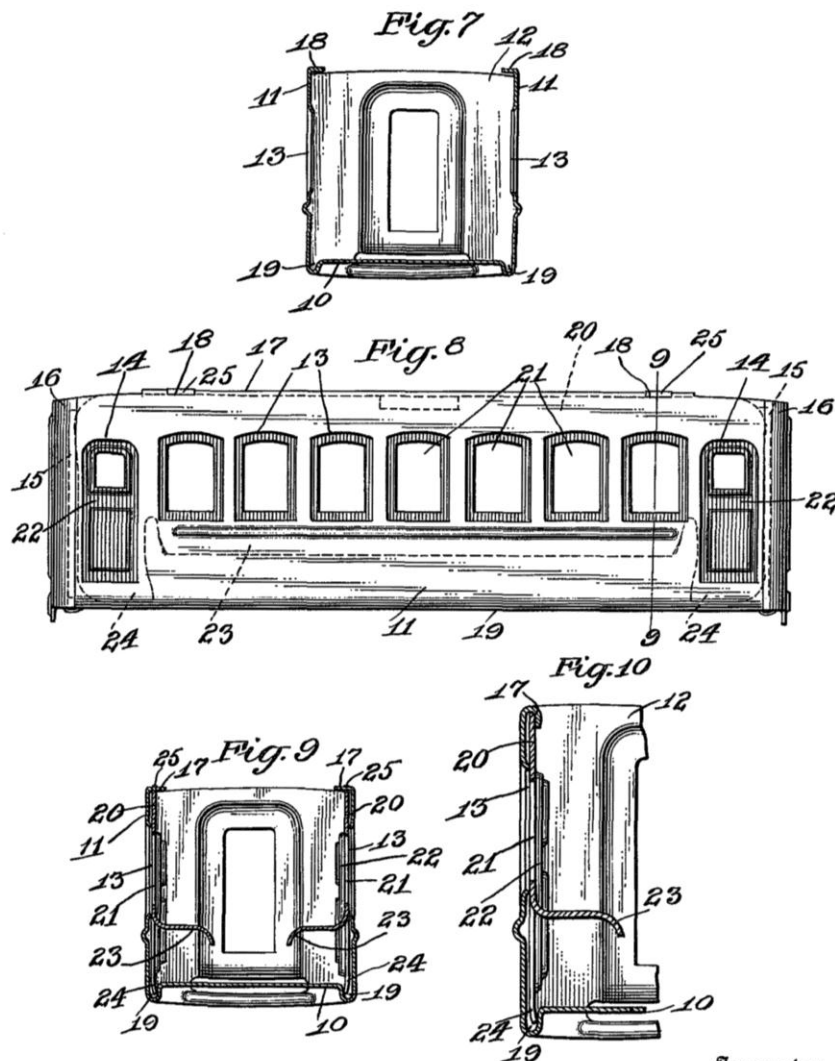

Inventor  
*Joshua L. Cowen*  
By his Attorney  
*Ashley Cohen*



SERVES THE UPSTATE

## GENERAL MEETING MINUTES

By **Ralph Watson,**  
**Stationmaster**

**July 5, 2012**

### Regular Meeting at the Central Railway Museum

The meeting was called to order on time at 7:15PM by President Dan Marett.

Twenty-seven members were in attendance.

A moment of silence was observed for two members, Richard Nichols and Ron Keith, who passed away in the past month. A memorial plaque honoring them and other past members is planned.

### WORK IN PROGRESS:

The role of Education Chairperson still needs a volunteer.

A grant check has been received from Pickens County in the amount of \$1800. There is still no word on the Walmart requests.

The flammables locker and policy have had no progress made to date.

Step-up benches for children to get a better view of the layouts are still under review.

Lionel Room walls are prepped for insulation; bids are being solicited.

Train Show dates are 2 and 3 February 2013. Contract with City of Easley and ad copy/art to be first steps.

An individual is needed to act as Ambassador to the Newcomers Club meetings in Seneca on the first Tuesday of the month from September to May.

Members who have not had photos taken for the web page please see Ed Welch or submit your own to Ed.

Funds from Central for the headlight artifact are pending.

Dan and Jack Green will be attending a meeting this month concerning the October Textiles and Rails exhibit in Greenville.

### COMMITTEE REPORTS:

**Treasurer's Report -- Bob Folsom.** Bank balance is adequate, expenses are within budget.

**Museum Building -- Glenn Nasworthy.** Nothing to report.

**Portable Layout -- Jim McInnis.** Track replacement is well underway, with 6 new modules to begin soon.

**American Flyer -- Dale Reynolds.** We have our first AF Diesel, a donation from Jim Davidson.

**Museum Curator -- Jack Green.** Nothing new. We are still working toward October 6 and 7 exhibit in Greenville.

**Property Inventory Administrator -- Steve Humphrey.** Nothing new.

**Web Master -- Ed Welch.** A page remembering our recently deceased members has been added to the web site.

**Railfan Reports -- Don Rumer** went with an OLLI group to Cass, WV and Roanoke. The Virginia Museum of Transportation is showing N&W J 611.

Roger Smith, Elliott Morgan, Don Baldwin, Glenn Nasworthy, and Mac McMillan went to Spencer for the gathering of the NS Heritage units. Please share your pictures!

Mac also reported a ride behind Southern No.630 which was enjoyed, but all the cars were closed and no one was allowed in the vestibules, diminishing the enjoyment of the trip.

**Lionel Room -- Mac McMillan.** A plan to create a layout “just one step improved over toy trains running on the floor in circles around the Christmas tree” will be built. Vintage items will be displayed and less esoteric hardware will operate.

**Newsletter -- Rob Seel.** Thanks to everyone for the contributions. Home layout tours/features/photo sessions can be set up for future issues. Contact Rob for scheduling. Please remember to take good quality digital photos by notching up the bit count setting on your camera.

**Electrical Work -- Howard Garner.** The paper mill wiring and switch motors are being installed.

**Trackwork -- Bob Folsom.** The paper mill spur and arrival yard are going down next.

**Operations Committee -- Howard Garner.** Nothing new.

**Scenery -- Sandy Eustis.** Scenic elements and buildings are being named to remember Ron and Richard.

**Publicity -- Ette Rupert.** No report.

#### OLD BUSINESS:

An ice cream and cake social for all members and families will be held at the museum on Friday, 13 July at 6:00PM.

#### NEW BUSINESS:

Our Payment-in-Kind service for the city is due soon.

Everyone be sure to relock the storage area when leaving.

#### PROGRAM:

Don Baldwin gave an interesting talk and showed photos from Scotland depicting rolling stock, station areas, work trains and bridges.



CRM&HA friend and former member **Pete Sheriff** sent in this photo of the new Piedmont & Northern Railway's two GP15-1 units (both ex-Conrail, blt 1979) parked in Gastonia, NC on July 19, 2012. Patriot Rail has revived the old P&N line for thirteen miles between Gastonia and Mount Holly, NC. Thank you, Pete! 



## GENERAL MEETING MINUTES

By **Ralph Watson,**  
**Stationmaster**

SERVES THE UPSTATE

**August 2, 2012**

### **Regular Meeting at the Central Railway Museum**

The meeting was called to order on time at 7:15 PM by Vice President Joe Fitzpatrick.

There were twenty members in attendance.

The Open house was very successful. Thanks go out to all who got the trains running, got the museum ready and helped with the refreshments.

The Memorial plaque is now hung in the meeting room.

### **WORK IN PROGRESS:**

The position of Education Chairperson remains open.

Sandy Eustis has started a folio of the descriptions of each of the identified scenes and the 'bones' -- benchwork, wiring, trackwork -- of the layout. Each area is described and explained for future reference. Photos of the construction process can be added. The book is kept in the third drawer of the tall filing cabinet. Everyone is encouraged to use it for reference and to contribute new pages. These pages could also be added to the web site.

Since the cabinet previously thought to be stored cannot be located the idea of using an explosion proof rag can costing from \$50-80 will be studied as a flammables locker.

A contractor has been engaged to install insulation in the Lionel Room.

Liability issues are a concern with the step-up benches in the Heritage Rooms. No plan is made yet.

Jim Reece is still actively "stirring" the Walmart grant pot.

Train Show dates are 2 and 3 February 2013. Ad copy and brochures will be needed soon. Howard will be sending out vendor packets in early September.

A volunteer is still needed to act as Ambassador to the Newcomers Club meetings for the first Tuesday morning of each month to attend a meeting at St Mark United Methodist Church in Seneca to promote new membership in our museum.

Jack Green reported that a planned meeting concerning the October Textiles and Rails exhibit in Greenville was not held, and there is uncertainty of sponsorship of the event.

### **COMMITTEE REPORTS:**

**Treasurers Report -- Bob Folsom.** Status Quo

**Museum Building -- Glenn Nasworthy.** Nothing to report; see note about insulation above.

**Portable Layout -- Jim McInnis.** Six new module bases are nearly completed.

**American Flyer -- Dale Reynolds.** No report.

**Museum Curator -- Jack Green.** No report.

**Property Inventory Administrator -- Steve Humphrey.** Nothing new to report.

**Web Master -- Ed Welch.** No report.

**Railfan Report -- Mac McMillan.** No report.



**Newsletter -- Rob Seel.** Please get your articles and good quality photos in early in the month.

**Electrical Work -- Howard Garner.** JT Thorpe reported that some of the tortoise switch machines were simply glued in place; when that failed the falling machine caused short circuits. All have been retrofitted with screws.

**Trackwork -- Bob Folsom.** Opportunities abound on the portable and museum layouts. The paper mill lead and Seneca Yard are two sites ready for work.

**Operations Committee -- Howard Garner.** A list of industries and cars required to service them is under development.

**Scenery -- Sandy Eustis.** Water has been added in the log pond and the stream bed near Pendleton. A lot of track remains to be painted and ballasted.

**Publicity -- Ette Rupert.** No report.

#### **OLD BUSINESS:**

A cash gift from Bill Moorhead has been added to the general funds.

#### **NEW BUSINESS:**

Membership cards for 2012 have been prepared. See Ralph to get yours.

#### **PROGRAM:**

Rob Seel presented an informative slide show on the New York City High Line history, uses, equipment and eventual ongoing conversion to a raised linear park.



The New York, Susquehanna & Western Technical and Historical Society operates a scenic excursion on weekends along the Delaware River from Phillipsburg to Carpentersville, NJ. The 2-8-2 No. 142 was built new by Tangshan in China, in 1989, with appliances added for a more American look. **Rob Seel** took this photo on Sunday afternoon, August 26, 2012 on the old Belvidere and Delaware River Railroad in Phillipsburg, NJ. 

# RUMER HAS IT!

## OLLI TRIP TO CASS & ROANOKE

BY DON RUMER



On June 27-30 a few of us took a railfanning trip sponsored by the Osher Lifelong Learning Institute (OLLI), an adult education organization affiliated with Clemson University. We stayed in Lexington, VA overnight and drove to Cass, WV the next morning. Ette Rupert and Bill Bridwell were organizers and did the driving. We took the longer train ride to Bald Knob, which has an elevation of around 4800 feet. Trip was about total of 4.5 hours with stopovers. We went through a couple of switchbacks near Whittaker station.





The Cass Scenic Railroad was originally an old logging railroad traversed by geared locomotives. Our locomotive for this visit was No. 6, a Shay built for coal service on the Western Maryland in 1945. It eventually ended up at the B&O museum where it was eventually exchanged for another Shay and Porter from the Cass Scenic Railroad. This locomotive's actual weight (162 tons) required significant upgrades to the Cass track.







On the way home, Friday, from Cass, we stopped at the Virginia Museum of Transportation in Roanoke. A retired employee of Norfolk Southern gave us a great tour of the railroad collection. The pride of the museum seems to be the Norfolk and Western Class J No. 611, a streamlined steam locomotive used for passenger service -- the one Bob Folsom often runs. This Class J is the only one in existence today.

Also on display is the N&W Class A No. 1218, an articulated 2-6-6-4 steam which was used both for freight and passenger service.

Other notables include Virginian EL-C electric No. 135 and Pennsylvania GG-1 No. 4919. This museum is well worth visiting in my opinion. We also visited the O. Winston Link Museum. He is famous for his photographs documenting the end of the steam era on the Norfolk and Western. Many of his photos are on the museum link sight: [www.linkmuseum.org](http://www.linkmuseum.org). 🚂



**Parting Shot:** New Hope & Ivyland No. 40 glides across Aquetong Creek with its 3:00 train to Lahaska on Sunday, August 26, 2012. **Photo by Rob Seel** 🚂