



CENTRAL CROSSINGS

MONTHLY NEWS LETTER OF THE

CENTRAL RAILWAY
MODEL & HISTORICAL ASSOCIATION, INC.

Volume 20, Number 7

July 2011

P. O. Box 128
Central, SC 29630

WEBSITE:
www.crmha.org

MUSEUM &
MEETING SITE
108 Werner Street
Central, SC

OFFICERS

President / CEO:
Jim Reece

Vice President:
Ron Keith

Stationmaster
Glenn Nasworthy

Paymaster
Bob Folsom

Webmaster
Ed Welch

Show Chairs:
Ette Ruppert &
Al Costa

Museum Curator:
Jack Green

Editor & Publisher:
Robert M. Seel, AIA

Next Meeting:
July 7, 2011
7:15 PM



SUMMER RAILS NEAR & FAR

In this month's issue, **Bruce Gathman**, **Howard Garner**, and **Sage Viehe** share their recent photos of the exciting, the unusual, and the average trains that all make great photo subjects. **Above:** **Bruce Gathman** captured BNSF ES44AC No.5847 leading a long string of loaded coal hoppers south toward Colorado Springs on the Joint Line (ex-ATSF) on June 13, 2011, just outside of Lockspur, Colorado. **Below:** **Howard Garner** snagged the Norfolk Southern Brass Hats making a rare Upstate appearance as the full set of Executive Fs blasted southward through Central the week before, on June 4, 2001. Great work, fellas!



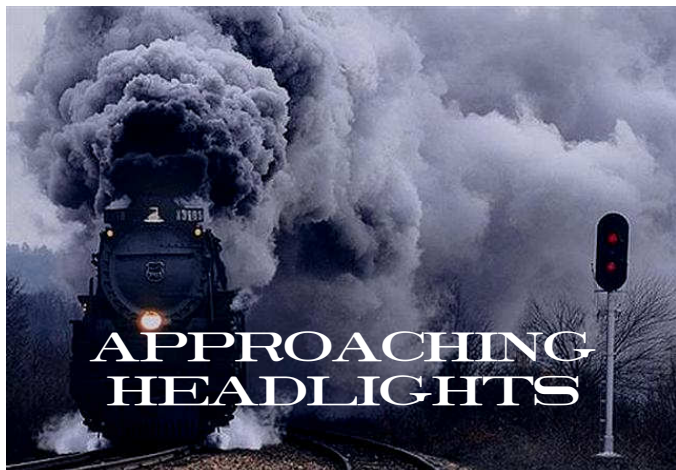

Upcoming Events for the
Central Railway Model & Historical Association
 as well as Regional shows and events worth mentioning

PROGRAM SCHEDULE

July 7, 2011	Perfect, Proper, Pretty People Painting Project Jim "Doc" McInnis
August 4, 2011	2010 National Narrow Gauge Convention, St. Louis Bruce Gathman
September 1, 2011	Need a Program! See Dale
October 6, 2011	Your Big Shot at Fame Sign up and don't miss it!
November 3, 2011	Opportunity Knocks! See Dale before he sees you
December 1, 2011	Christmas Dinner, TBA

SCHEDULED EVENTS & SHOWS

July 21-24, 2011

Rock Island, IL

Train Festival 2011

Steam Excursions and Exhibits!

Nickel Plate 765 (4-8-2)

Iowa Interstate 6988 and 7081 (both Chinese 2-10-2)

Leviathan 63 (4-4-0), Flagg Coal 75 (0-4-0)

Lehigh Valley 126 (0-6-0), Viscose 6 (0-4-0T)

Plus live steam, riverboat rides, models, displays, and diesels, and music by James Coffey too.

www.trainfestival2011.com

August 13, 2011

Norcross, GA

41st Atlanta Model Train Show

North Atlanta Trade Center

9:00 – 4:00 www.gserr.com

\$6.00 / Children 12 and under Free

September 2-5, 2011

Chattanooga, TN

Tennessee Valley Railfest

Tennessee Valley Railroad Museum's 50th Birthday!

Steam excursions, music, night photo session

www.tvrail.com

September 7-10, 2011

Hickory, NC

National Narrow Gauge Convention

Hickory Metro Convention Center

www.tarheelpress.com/ngc

October 8, 2011

Hendersonville, NC

French Broad eNpire's Autumn Rails 2011

Whitmire Activity Center

10:00 – 3:00 www.fbe-ntrak.com

\$5.00 / Children under 13 and Scouts in Uniform Free

October 15-16, 2011

Myrtle Beach, SC

Myrtle Beach Model Train Show

Lakewood Conference Center

More info coming.

2ND SATURDAY

**MUSEUM OPEN TO
THE PUBLIC**

**COME RUN TRAINS & HAVE SOME
FUN!**

**JULY 9, 2011
AUGUST 13, 2011**



SERVES THE UPSTATE

GENERAL MEETING MINUTES

By Glenn Nasworthy,
Stationmaster

June 2, 2011

Regular Meeting at the Central Railway Museum

The meeting was called to order by President Jim Reece. Twenty two members were in attendance.

There was one guest present, John Thorpe, who was one of the original members of the club

The Treasurer reported that the state of the treasury is good.

OLD BUSINESS:

There are no reimbursements from the City for the month of April. The project-to-date receipts are \$14176.12. We need any invoices for May expenditures.

We will proceed with the hosting of the Palmetto Div NMRA meeting on October 29th. Ed Welch has arranged for us to use Founders Hall at Southern Wesleyan for this meeting. Howard Garner has notified the Palmetto Division.

Jim announced that we have received a \$2,500 Pickens County Accommodations grant. We have to submit a W-9 form to complete this. The form will be mailed tomorrow.

The Tourism Stakeholders Conference was held May 19th. Jack Green and Ette Ruppert represented us. In general, the purpose of the conference was to get everyone in the county on the same page regarding tourism.

A meeting regarding the next Train Show is to be set up with the Mayor and Facilities Director in Easley at the earliest convenient date.

We will have three Cub Scout Packs visit the Museum on Saturday the 18th at 10:00 AM. We will need to have trains running at that time.

A discussion on a Boy Scout merit badge was delayed due to Joe Fitzpatrick's absence.

"Central Crossings" correction: Regarding the Easley Train Show, if we pay a percentage of the gate we will not have to pay for security and safety personnel. *(Thank you for reading the newsletter to notice this error ~ ed.)*

President Jim Reece asked those on the Steering Committee to meet on June 7, 2011.

COMMITTEE REPORTS:

Train Show: Delayed until the meeting with the City of Easley.

Museum Building: We have filled our guest book! A new one will be purchased.

Central Railroad Festival: No discussion due to Ron Keith's absence.

Portable Layout: Jim McInnis said they are trying to figure out how a walk through gate can be put in to make entrance into the operating area easier.

Lionel Room: Nothing to report. No work being done until the room can be available.

American Flyer: Mac MacMillin said he could not find anything wrong with a transformer that had been reported as running hot. He felt there may have been a short on the track that was not quickly resolved.

Programs: Dale Reynolds was absent so there was no report.

Webmaster: The web page is up and running again after some downtime. Ed said to be sure to include the www. in the web address when trying to get on.

Newsletter: Rob Seel again asked people for their pictures and made a plea for material for the next newsletter. *(See the fantastic response in this month's issue! ~ ed.)*

Museum Curator: Jack Green said the inventory program is working well.

Property Inventory Administrator: Steve Humphries is now the administrator. He is loading inventory data in the software.

Computer Administrator: Howard Garner reported nothing new.

HO Layout:

Benchwork: Unless we make changes the benchwork is finished.

Wiring: Wiring is keeping up with trackwork. The 200 block shorted out and is being corrected. The Biltmore and Peachtree yards are now functional.

Scenery: We have some new rock moulds. We are making progress on scenery including track ballasting.

Rolling Stock: Jim McInnis said is working on the Southerner. Several of the cars are complete and when finished the train will be “by the book”.

Trackwork: Bob Folsom said his budget is exhausted and trackwork is still in progress.

NEW BUSINESS:

There was no new business.

The meeting was adjourned.

There was no program due to Ron Keith’s absence.



On the afternoon of Monday, June 6, 2011 **Howard Garner (photo)** caught a rail grinding operation disturbing the peace in downtown Seneca. Loram (LMIX) grinder train set No. RG 314 is seen here at the Walnut Street crossing, near the depot. Loram Maintenance of Way, Inc has provided various infrastructure maintenance services to railroads since 1954, including ditching, grinding, ballast cleaning, and excavating. Rail grinding is a procedure that restores the profile of rail from wear fatigue, dipped welds, corrugation, and side wear, among others. Not only does grinding extend the serviceable life of the rail, but also every wheel and axle that rolls on it, making for faster and smoother rides. Train sets like this one include several grinder units and water tank cars. A converted caboose on the end has water spray nozzles mounted the rear platform, by which the crew extinguishes sparks and cools the hot rail. 

COLORADO IN JUNE

Photos by Bruce Gathman

Bruce captured the two helper units on the same coal train shown on Page 1, easing the train along at 10 mph, dynamic brakes working hard. Both helpers, 6301 and 5883 are ES44AC units.

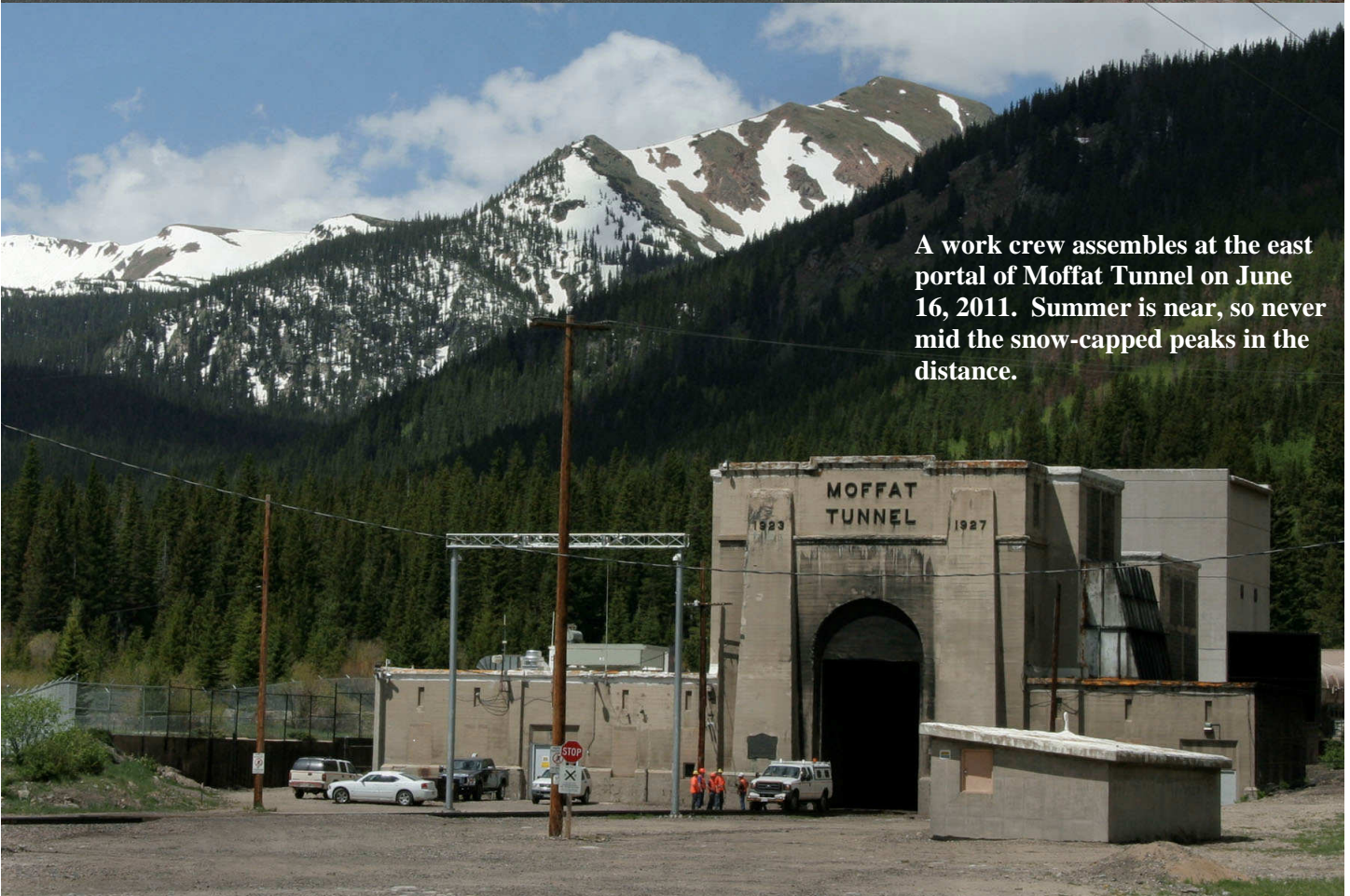

A work crew assembles at the east portal of Moffat Tunnel on June 16, 2011. Summer is near, so never mid the snow-capped peaks in the distance.



Not far from Moffat Tunnel, UP AC44CW No. 6773 (radio controlled) assists two other helper units on the point for a total of six locomotives. Bruce Gathman photographed this 60-car manifest freight through Rollins Pass (near Rollinsville, CO) on June 16, 2011.

ANDERSON LOCAL: BETTER LATE!



Sage Viehe (photo montage) caught the Anderson Local on a rare daylight run the afternoon of May 25, 2011. The four-unit consist on this day was comprised of GP50 No. 7016 (ex-SOU, blt 1980) in old Southern long hood foreword fashion followed by sister unit, No. 7078 (ex-SOU, blt 1981), GP38-2 No. 5326 (ex-CR 8154, nee-PC 8145, blt 1973), and NS Operation Lifesaver GP59 No. 4629 (blt 1989). The Anderson branch is the former Blue Ridge line running from Seneca, through Pendleton and Sandy Springs, to interchange with the Pickens Railway in downtown Anderson. The manifest freight train usually runs its turn over night, so daylight exposure is quite rare. 🚂



MEETING MINUTES

By Glenn Nasworthy,
Stationmaster

SERVES THE UPSTATE

June 7, 2011

STEERING COMMITTEE Meeting at the Central Railway Museum

Present: Jim Reece, Bob Folsom, Ette Ruppert, Sandy Eustis, Howard Garner & Glenn Nasworthy

GENERAL:

The Palmetto Division NMRA meet to be held October 29th, 2011 as discussed. Howard Garner is our contact person. We need some layout tours lined up, Howard Garner is one, and Rob Seel is to be asked to do a training clinic. The representatives from NMRA are to visit Thursday June 9th to review the facility, Freedom Hall at Southern Wesleyan University.

Cub Scouts are scheduled to visit the museum on Saturday June 18th at 10:00 AM. We need trains running including the American Flyer layout.

It was agreed that we want the museum layout on display for the National Narrow Gauge Convention. This is to be September 9th or 10th, 2011.

LAYOUT:

The time period for the layout is fall of 1958. The lower level is late summer, the second level is early fall and the third level is late fall.

We are to concentrate on finishing the upper level within the next three months and then start on the lower level.

After the upper level our priorities are:

1. Backdrop for the Seneca yard.
2. Ask Rob to provide a mockup of Central. How is it going to fit? What will be there; Central Station, Central Plaster, the mill?

3. Seneca yard needs to be laid out. Make cardboard mockups.

Our scenic priorities are:

1. Quarry corner
2. Back corner between front and back rooms.
3. Sawmill through narrow gauge

It was decided by those present that Central needs more depth. Therefore, the road bed is to be moved closer to the aisle. No more track is to be laid until this is done.

TRAIN SHOW:

Jim Reece, Bob Folsom, and Glenn Nasworthy are to meet with the Easley officials to work out a contract for the 2012 show to be held the first weekend in February 2012. 

STONE STATION TO BE DEMOLISHED

But Exciting Things are in the Works!



After a structural engineering analysis, the Town of Central has decided that it is financially unfeasible to preserve the old stone service station (circa 1936) on the corner of Main and Church streets. The stone masonry exhibits significant cracks that will lead to eventual failure. As it stands, the building has been condemned and declared unsound. The Town desires to develop a Heritage Plaza on this site to not only preserve the memory of this building but also to further propagate the history of Central. Our own Rob Seel has been contacted by Mayor Mac Martin, Administrator Philip Mishoe, and Ass't Admin. Tom Cloer to brainstorm and develop a design for the site. Rob has also met with Beverly Cureton and Anne Sheriff of the Historical Society for their considerations. Stay Tuned!!! 

PATENTLY SPEAKING

Submitted by Bruce Gathman

There are generally two parts to patent submissions: a written description of the invention and drawings (not to scale) that are keyed to this written description. Depending on the complexity of the invention more than one page of descriptions and/or drawings may be required to fully explain the merits of the design. You may find these descriptions online at—<http://patft.uspto.gov/netahtml/PTO/patimg.htm> by entering the patent number in the “view patent” box.

E. R. IVES.
AUTOMATIC TOY.

No. 176,961.

Patented May 2, 1876.

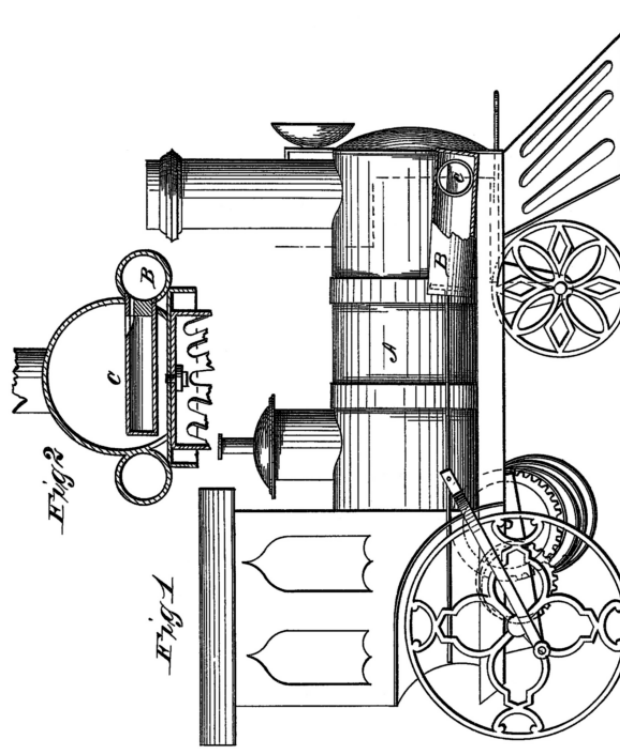

WITNESSES
Frank L. Ostland
By
C. L. Frost

INVENTOR
Edw. R. Ives
Alexander M. Mason
Attorneys.

A. PETERS, PHOTO-LITHOGRAPHER, WASHINGTON, D. C.

Be it known that I, EDWARD E. IVES, of Bridgeport, in the county of Fairfield, and in the State of Connecticut, have invented certain new and useful Improvements in Mechanical Toys; and do hereby declare that the following is a full, clear, and exact description thereof, reference being had to the accompanying drawings, and to the letters of reference marked thereon, making a part of this specification.

The nature of my invention relates to that class of toys, which are propelled by spring actuated mechanism, when combined with a whistle or other device for producing sounds of that kind, said sounds being produced by the agency of the mechanism when the toy is in motion, as will be hereinafter described.

